



ELSA 3

LED-1L15E500BT14/027 DALI 4K#

WWW.OSMONT.CZ

ELSA 3

Product code: ELS68568

Type: LED-1L15E500BT14/027 DALI 4K#

Short description of the luminaire: White surface-mounted LED light DALI with TRIPLEX OPAL glass shade.



Technical

| | |
|------------------------------|--------------------------------|
| Types of luminaires | Dimmable |
| Mounting type | surface mounted |
| Base material | steel |
| Shade material | three-layer glass TRIPLEX OPAL |
| Base color | white Ral9003 |
| Shade color | white |
| Holding the shade | bayonet |
| Mounting location | ceiling/wall |
| Width | 360 mm |
| Length | 360 mm |
| Height | 88 mm |
| Diameter | ø 360 mm |
| mounting holes (diameter) | 3xø5mm |
| Installation wire (diameter) | 2xø16mm |
| Energy Class | D |
| Impact strength | IK01 |
| Operating temperature | from -20°C to +30°C |

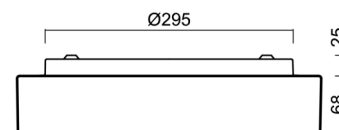
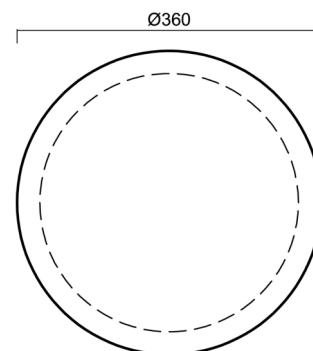

Electric

| | |
|-------------------------------------|---------------------|
| Power consumption | 19 W |
| Ingress Protection | IP44 |
| Socket | LED modul |
| terminal block | snap terminal block |
| Automatic circuit breaker type B10A | 31 pcs |
| Automatic circuit breaker type B16A | 50 pcs |
| Automatic circuit breaker type C10A | 52 pcs |
| Automatic circuit breaker type C16A | 85 pcs |

Luminous

| | |
|-----------------------------|--------------|
| Lum. flux of luminaire | 2190 lm |
| Lum. flux of light source | 3130 lm |
| Luminaire efficacy | 115 lm/W |
| Temperature | 4000 K |
| Rated life time LED L80/B10 | 100000 hours |
| CRI | Ra80 |
| MacAdam | 3 |
| Blue light hazard | Risk group 0 |

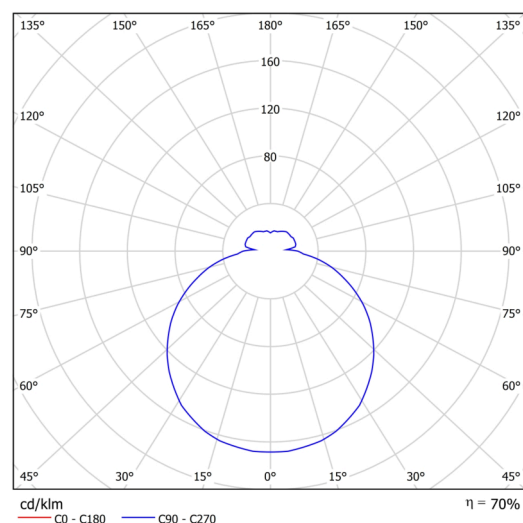

Eulum data for calculation programs are available at www.osmont.cz.

Logistic

| | |
|-------------------|----------------------|
| EAN | 8591728096595 |
| Weight NTTO | 3.1 Kg |
| Weight BTTO | 3.4 Kg |
| Number of cartons | 1 pcs |
| Package volume | 0.016 m ³ |
| Package 1 width | 0.375 m |
| Package 1 length | 0.355 m |
| Package 1 height | 0.12 m |
| Warranty* | 60 months |

*The warranty for the batteries is valid for 12 months from the date of purchase.

Installation dimensions:

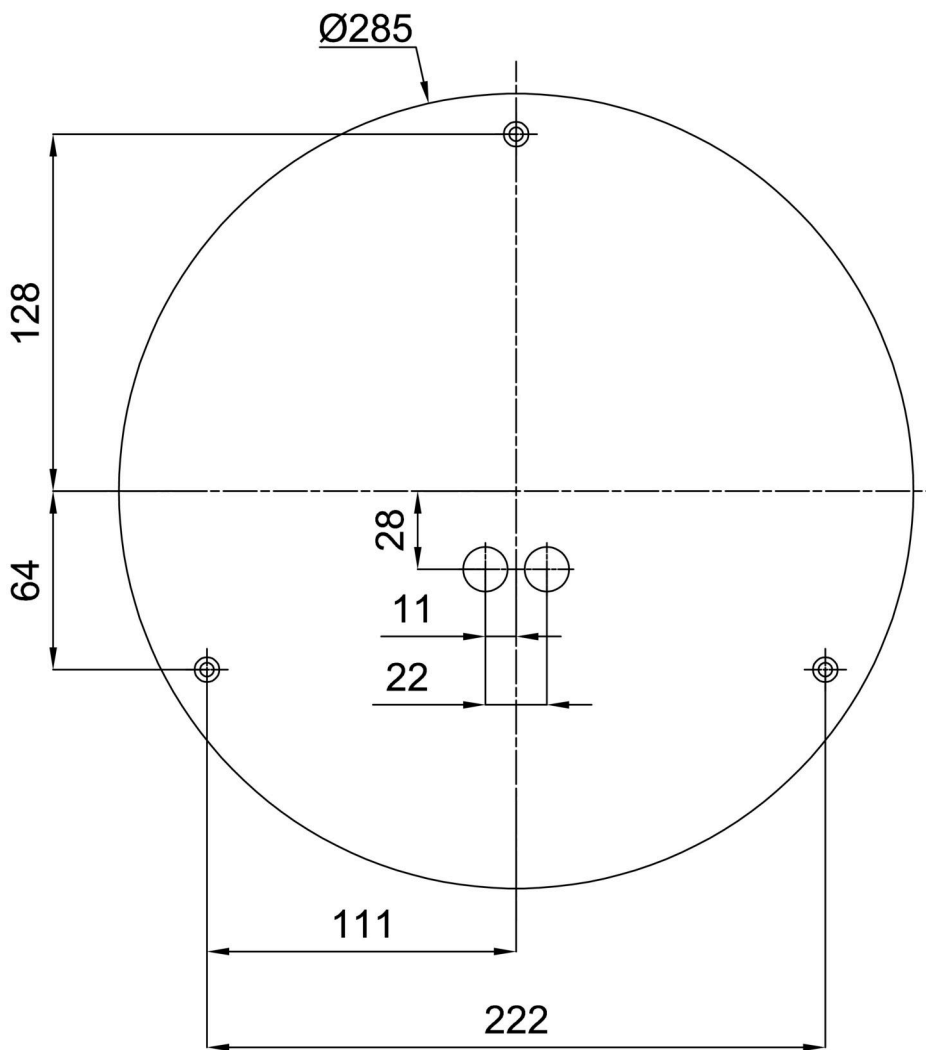

Lampshade

| Product code | Name | Color | Description | Picture | Drawing |
|--------------|------|-------|-------------|--|---------|
| 20082 | 027 | white | |  | |