



DELIA C2A

LED-1L17EMP700KN73/PC19C/NK1W HF 3K#

WWW.OSMONT.CZ

DELIA C2A

Product code: DEL73025

Type: LED-1L17EMP700KN73/PC19C/NK1W HF 3K#

Short description of the luminaire: White color | surface-mounted LED light | emergency combi unit with microwave HF sensor | multipower function | polycarbonate shade | black decorative foil stripe

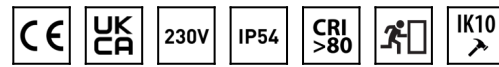

Technical

Types of luminaires	Emergency combined + sensor
Mounting type	surface mounted
Base material	steel
Shade material	opal polycarbonate
Base color	white Ral9003
Shade color	white - black
Holding the shade	folding system
Mounting location	ceiling/wall
Width	360 mm
Length	360 mm
Height	71 mm
Diameter	ø 360 mm
mounting holes (diameter)	3xø5mm
Installation wire (diameter)	2xø16mm
Energy Class	D
Impact strength	IK10
Operating temperature	from -20°C to +30°C

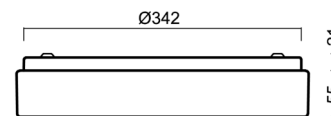
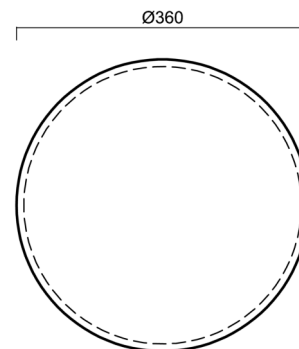

Electric

Power consumption	25 W
Ingress Protection	IP54
Socket	LED modul
Sensor	HF
Battery type	NiCd
Emergency time	3 hours
terminal block	snap terminal block
Automatic circuit breaker type B10A	26 pcs
Automatic circuit breaker type B16A	40 pcs
Automatic circuit breaker type C10A	30 pcs
Automatic circuit breaker type C16A	48 pcs

Luminous

Lum. flux of luminaire	2070 lm
Lum. flux of light source	3770 lm
Lum. flux of light source in emergency mode	150 lm
Luminaire efficacy	82 lm/W
Temperature	3000 K
Rated life time LED L80/B10	100000 hours
CRI	Ra80

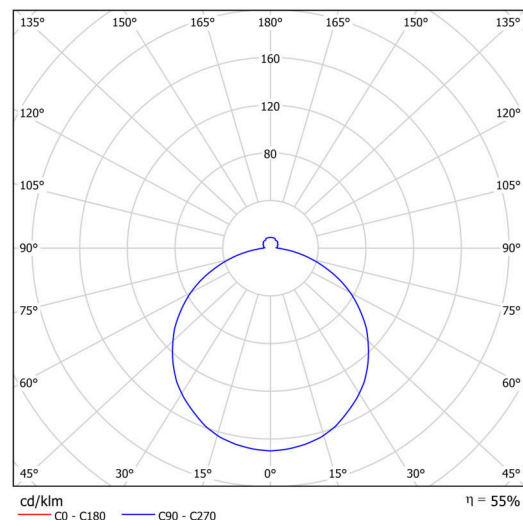

TECHNICAL SHEET



MacAdam	3
Blue light hazard	Risk group 0

*Eulum data for calculation programs are available at
www.osmont.cz.*

Multipower

Possibility of output adjustment by the user (DIP switch on the current source).

I [mA]	700	600	500	400	
[%]	100	86	71	57	

Logistic

EAN	8591728080181
Weight NTTO	1.65 Kg
Weight BTTO	2.05 Kg
Number of cartons	1 pcs
Package volume	0.019 m ³
Package 1 width	0.385 m
Package 1 length	0.37 m
Package 1 height	0.13 m
Warranty*	60 months

**The warranty for the batteries is valid for 12 months from the date of purchase.*

Installation dimensions:

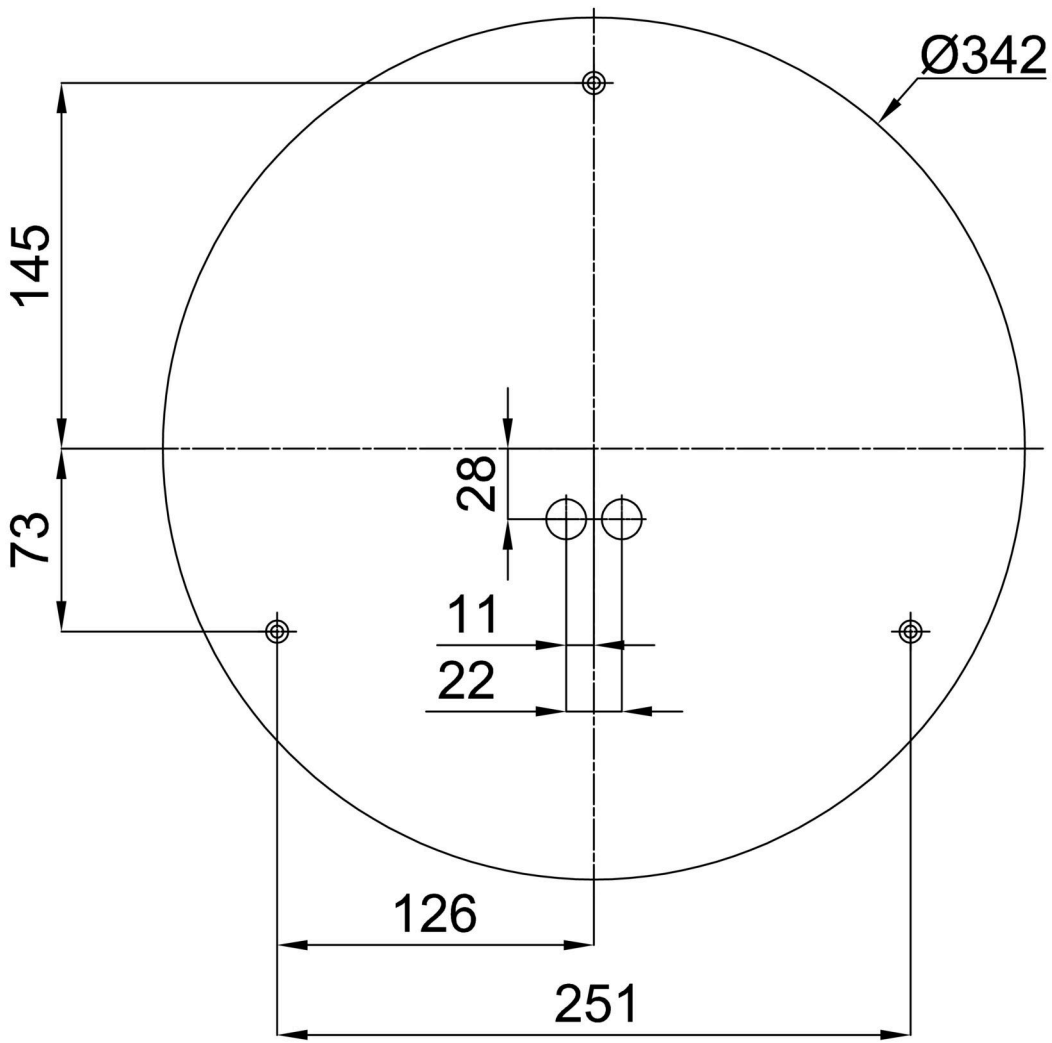

Additional assortment:

Lampshade

Product code	Name	Color	Description	Picture	Drawing
20567	PC19C	white - black		