



## DELIA C1

---

IN-12KN62/PC22C HF\*

[WWW.OSMONT.CZ](http://WWW.OSMONT.CZ)

# DELIA C1

Product code: DEL52588

Type: IN-12KN62/PC22C HF\*

Short description of the luminaire: White surface-mounted E27 light with sensor and polycarbonate shade.

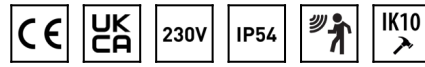

## Technical

Types of luminaires	Sensor
Mounting type	surface mounted
Base material	steel
Shade material	opal polycarbonate
Base color	white Ral9003
Shade color	white - black
Holding the shade	folding system
Mounting location	ceiling/wall
Width	300 mm
Length	300 mm
Height	75 mm
Diameter	ø 300 mm
mounting holes (diameter)	3xø5mm
Installation wire (diameter)	2xø16mm
Impact strength	IK10
Operating temperature	from -20°C to +30°C

## Electric

Voltage type	AC
AC voltage	220 - 240 V
Power consumption	25 W
Ingress Protection	IP54
Socket	E27
Sensor	HF
terminal block	snap terminal block

## Luminous

Blue light hazard	Risk group 0
-------------------	--------------

Eulum data for calculation programs are available at [www.osmont.cz](http://www.osmont.cz).

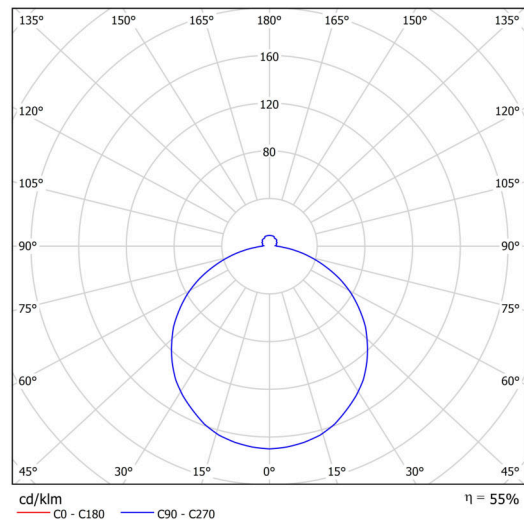
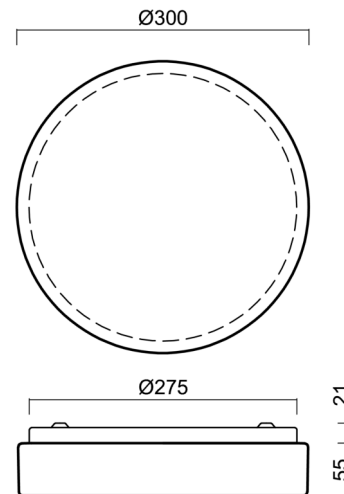

Logistic

EAN	8591728525880
Weight NTTO	0.9 Kg
Weight BTTO	1.1 Kg
Number of cartons	1 pcs
Package volume	0.01 m <sup>3</sup>
Package 1 width	0.31 m
Package 1 length	0.31 m
Package 1 height	0.1 m
Warranty*	60 months

\*The warranty for the batteries is valid for 12 months from the date of purchase.

Installation dimensions:



Additional assortment:

Base for surface mounting

Product code	Name	Color	Description	Picture	Drawing
33501	KN6,K6/BP	white Ra19003			

Lampshade

Product code	Name	Color	Description	Picture	Drawing
20566	PC22C	white - black		