



ADRIA S3A HP

LED-5L06E900ZS11/097/L100 NK3HST C 4K#

WWW.OSMONT.CZ

ADRIA S3A HP

Product code: ADR50906

Type: LED-5L06E900ZS11/097/L100 NK3HST C 4K#

Short description of the luminaire: Black colour | pendant LED light with emergency backup combined (with Self-test) | TRIPLEX OPAL hand blown glass shade| cable pendant (with inner support wire) 100 cm |

Technical data

| | |
|---------------------------|--------------------------------|
| Types of luminaires | Emergency combined SELFTEST |
| Mounting type | Suspended - cable |
| Base material | steel |
| Shade material | three-layer glass TRIPLEX OPAL |
| Base color | black Ral9005 |
| Shade color | white |
| Holding the shade | steel holder |
| Mounting location | ceiling |
| Width | 350 mm |
| Length | 350 mm |
| Height | 350 mm |
| Diameter | ø 350 mm |
| Suspension length | 1000 mm |
| mounting holes (diameter) | none |
| Energy Class | D |
| Impact strength | IK01 |
| Operating temperature | from +5°C to +30°C |

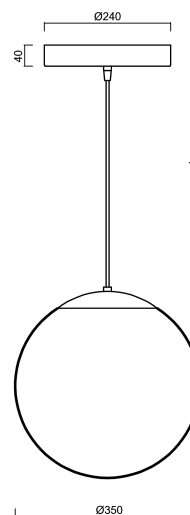

Electrical data

| | |
|-------------------------------------|-----------|
| Power consumption | 43 W |
| Ingress Protection | IP40 |
| Socket | LED modul |
| Battery type | LiFePO4 |
| Emergency time | 3 hours |
| SELFTEST | yes |
| terminal block | none |
| Automatic circuit breaker type B10A | 7 pcs |
| Automatic circuit breaker type B16A | 12 pcs |
| Automatic circuit breaker type C10A | 13 pcs |
| Automatic circuit breaker type C16A | 21 pcs |
| Number of LED drivers | 1 |

Luminous data

| | |
|---|----------|
| Lum. flux of luminaire | 5870 lm |
| Lum. flux of light source | 6670 lm |
| Lum. flux of light source in emergency mode | 200 lm |
| Luminaire efficacy | 136 lm/W |



TECHNICAL SHEET

| | |
|-----------------------------|--------------|
| Chromaticity temperature | 4000 K |
| Rated life time LED L80/B10 | 100000 hours |
| CRI | Ra80 |
| MacAdam | 3 |
| Blue light hazard | Risk group 0 |

Eulum data for calculation programs are available at www.osmont.cz.

Logistical data

| | |
|-----------|---------------|
| EAN | 8591728207717 |
| Warranty* | 60 months |

*The warranty for the batteries is valid for 36 months from the date of purchase.

Installation dimensions:

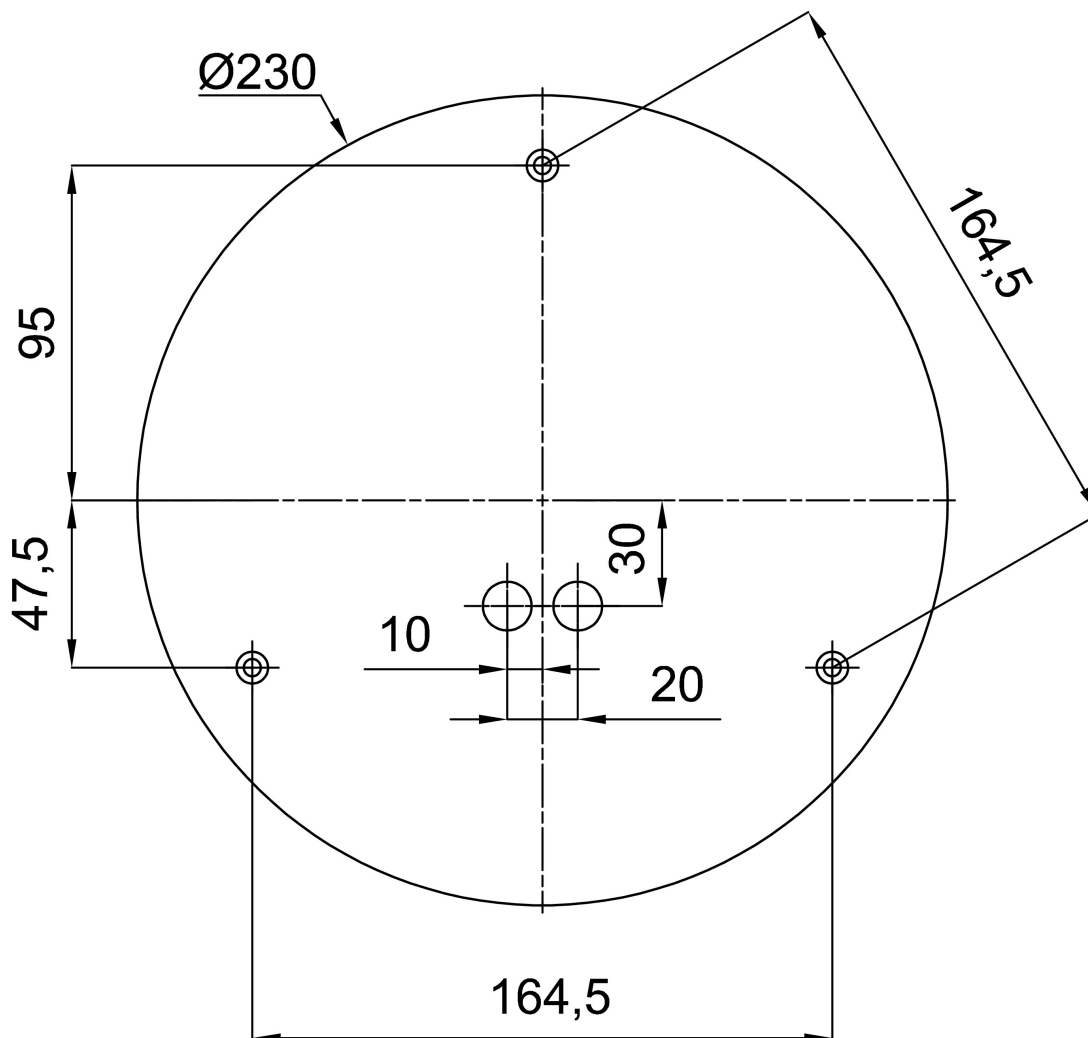

Additional assortment:

Lampshade

| Product code | Name | Color | Picture | Drawing |
|--------------|------|-------|---|---------|
| 20144 | 097 | white |  | |