



ZETA 2 PF

LED-3L65E1050K2H/PF92 GB DALI 3K##

WWW.OSMONT.CZ

ZETA 2 PF

Product code: ZET60043

Type: LED-3L65E1050K2H/PF92 GB DALI 3K##

Short description of the luminaire: Golden beach color | surface-mounted LED light | dimmable DALI | indirect lighting version | PMMA matt shade



Technical

Types of luminaires	Dimmable
Mounting type	surface mounted
Base material	steel
Shade material	opal polymethyl methacrylate
Base color	Golden Beach RAL1015
Shade color	white - Golden Beach
Mounting location	ceiling/wall
Width	600 mm
Length	600 mm
Height	105 mm
Diameter	ø 600 mm
mounting holes (diameter)	3xø5mm
Installation wire (diameter)	2xø16mm
Energy Class	C
Operating temperature	from -20°C to +30°C

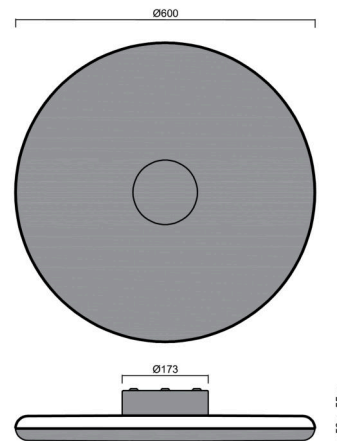

Electric

Power consumption	38 W
Ingress Protection	IP40
Socket	LED modul
terminal block	snap terminal block
Automatic circuit breaker type B10A	31 pcs
Automatic circuit breaker type B16A	50 pcs
Automatic circuit breaker type C10A	52 pcs
Automatic circuit breaker type C16A	85 pcs

Luminous

Lum. flux of luminaire	4450 lm
Lum. flux of light source	6370 lm
Luminaire efficacy	117 lm/W
Temperature	3000 K
Rated life time LED L80/B10	100000 hours
CRI	Ra80
MacAdam	3
Blue light hazard	Risk group 0

Eulum data for calculation programs are available at www.osmont.cz.

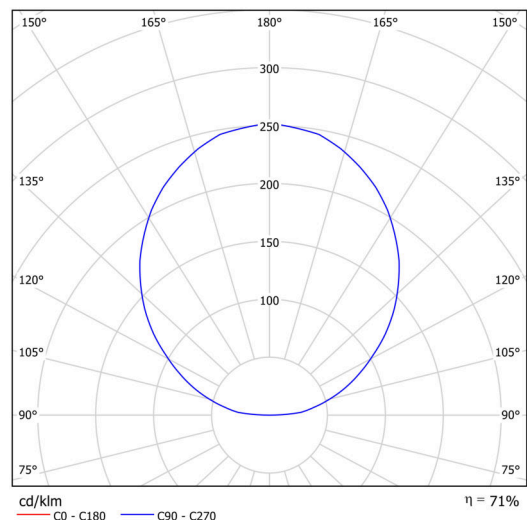

Logistic

EAN	8591728090708
Weight NTTO	5.5 Kg
Weight BTTO	6.3 Kg
Warranty*	60 months

*The warranty for the batteries is valid for 12 months from the date of purchase.

Installation dimensions:

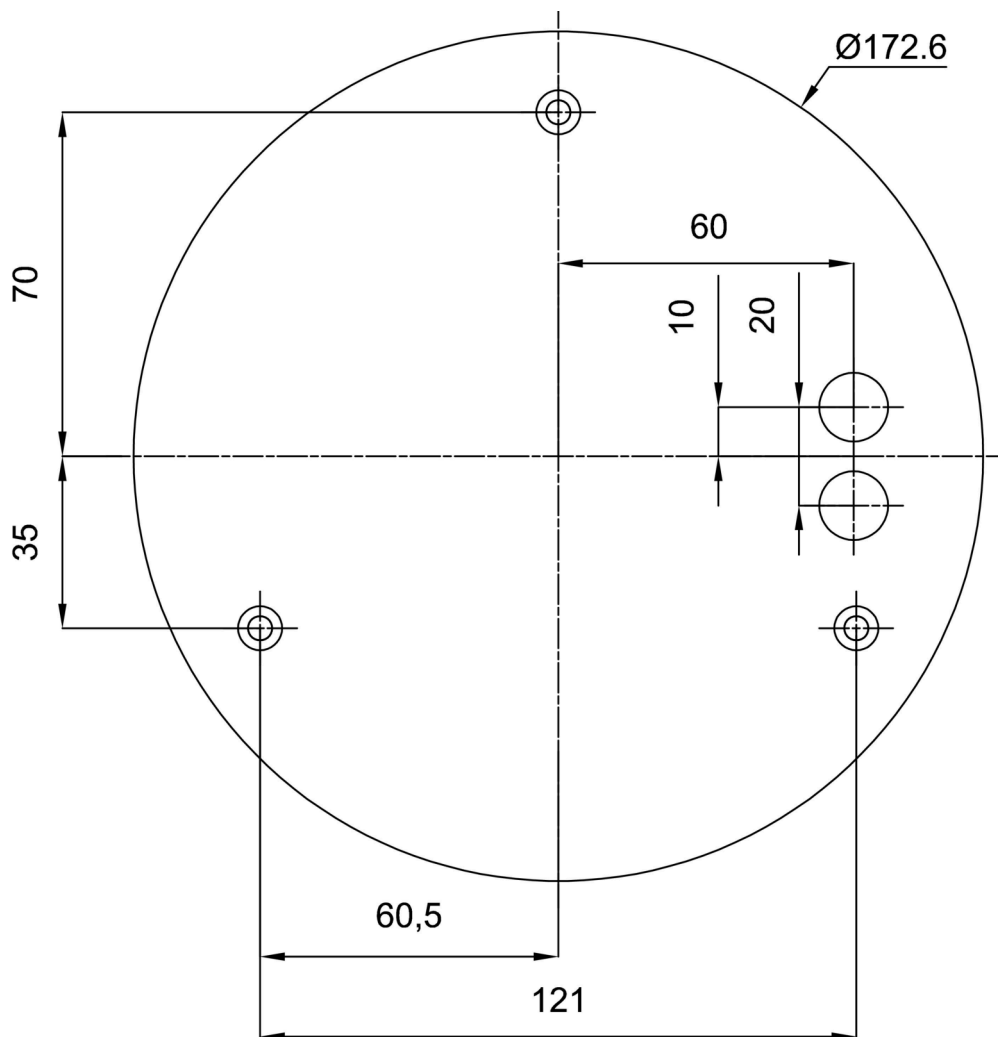

Additional assortment:

Lampshade

Product code	Name	Color	Description	Picture	Drawing
20669	PM92	white			