



TRITON 2

LED-1L15EMP700/IN-184 C 3K#

WWW.OSMONT.CZ

TRITON 2

Product code: TRI57286

Type: LED-1L15EMP700/IN-184 C 3K#

Short description of the luminaire: Black industrial LED light ON/OFF and polycarbonate shade.

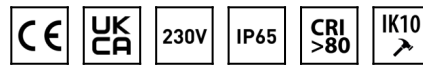

Technical

| | |
|------------------------------|---------------------|
| Types of luminaires | Classic on/off |
| Mounting type | industrial |
| Base material | polycarbonate |
| Shade material | opal polycarbonate |
| Base color | black Ral9005 |
| Shade color | white |
| Holding the shade | bayonet |
| Mounting location | ceiling/wall |
| Width | 360 mm |
| Length | 360 mm |
| Height | 108 mm |
| Diameter | ø 360 mm |
| mounting holes (diameter) | 3xø5mm |
| Installation wire (diameter) | 2xø16mm |
| Energy Class | D |
| Impact strength | IK10 |
| Operating temperature | from -20°C to +30°C |

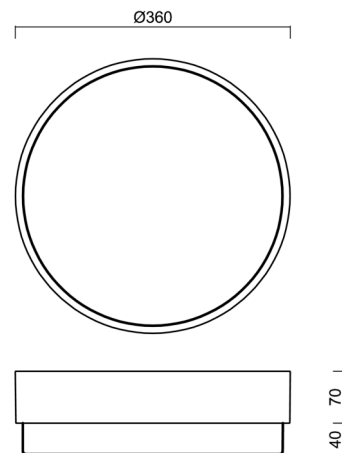

Electric

| | |
|-------------------------------------|---------------------|
| Power consumption | 27 W |
| Ingress Protection | IP65 |
| Socket | LED modul |
| terminal block | snap terminal block |
| Automatic circuit breaker type B10A | 37 pcs |
| Automatic circuit breaker type B16A | 59 pcs |
| Automatic circuit breaker type C10A | 37 pcs |
| Automatic circuit breaker type C16A | 59 pcs |

Luminous

| | |
|-----------------------------|--------------|
| Lum. flux of luminaire | 3310 lm |
| Lum. flux of light source | 4040 lm |
| Luminaire efficacy | 122 lm/W |
| Temperature | 3000 K |
| Rated life time LED L80/B10 | 100000 hours |
| CRI | Ra80 |
| MacAdam | 3 |
| Blue light hazard | Risk group 0 |

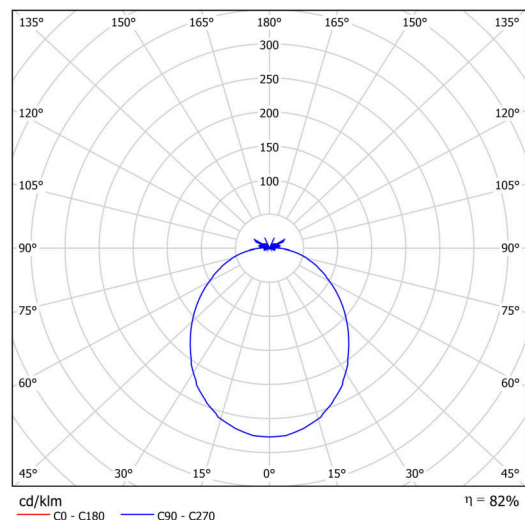

Eulum data for calculation programs are available at www.osmont.cz.

TECHNICAL SHEET

Multipower

Possibility of output adjustment by the user (DIP switch on the current source).

| | | | | | |
|--------|-----|-----|-----|-----|--|
| I [mA] | 700 | 600 | 500 | 400 | |
| [%] | 100 | 86 | 71 | 57 | |

Logistic

| | |
|-------------------|----------------------|
| EAN | 8591728134174 |
| Weight NTTO | 1.5 Kg |
| Weight BTTO | 1.8 Kg |
| Number of cartons | 1 pcs |
| Package volume | 0.019 m ³ |
| Package 1 width | 0.39 m |
| Package 1 length | 0.37 m |
| Package 1 height | 0.13 m |
| Warranty* | 60 months |

*The warranty for the batteries is valid for 12 months from the date of purchase.

Installation dimensions:

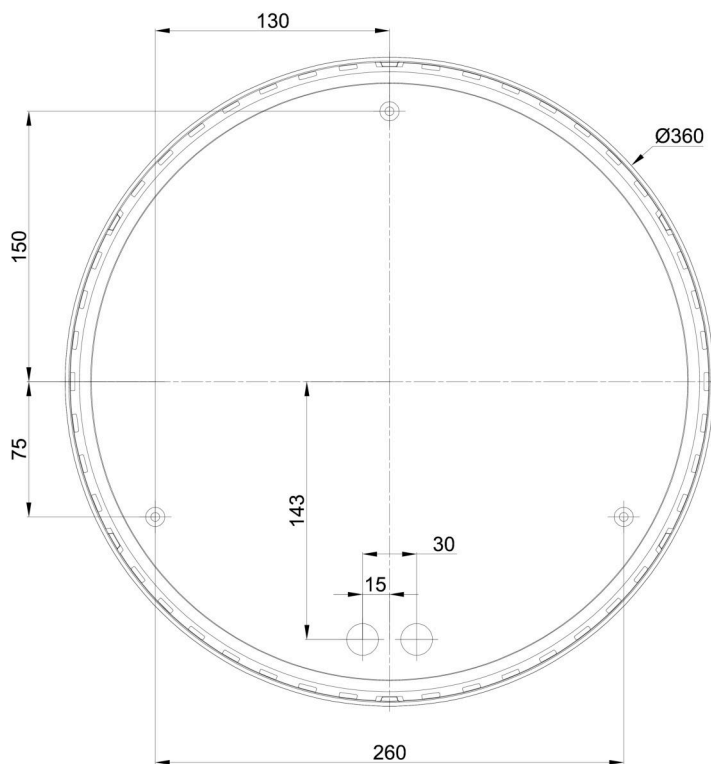

Additional assortment:

Lampshade

| Product code | Name | Color | Description | Picture | Drawing |
|--------------|------|-------|-------------|---|---------|
| 20550 | 184 | white | |  | |