

KRUGER P1 F0

LED-1L14ET700ZKN62/F01B/z5 B BT 27-65K#

WWW.OSMONT.CZ

KRUGER P1 F0

Product code: KRU61025

Type: LED-1L14ET700ZKN62/F01B/z5 B BT 27-65K#

Short description of the luminaire: White color | pendant LED light | Bluetooth Tunable White system | opal plastic shade | decorative collar

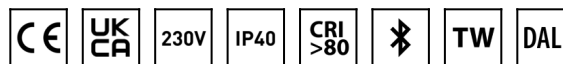

Technical

Types of luminaires	Tunable White
Mounting type	Suspended - rod
Base material	steel
Shade material	Plastic opal (F0) with metal collar
Base color	white Ral9003
Shade color	white
Holding the shade	folding system
Mounting location	ceiling
Width	300 mm
Length	300 mm
Height	80 mm
Diameter	ø 300 mm
Hinge length	1000 mm
mounting holes (diameter)	3xø5mm
Installation wire (diameter)	2xø16mm
Energy Class	D
Operating temperature	from -20°C to +30°C

Electric

Power consumption	18 W
Ingress Protection	IP40
Socket	LED modul
terminal block	snap terminal block
Automatic circuit breaker type B10A	22 pcs
Automatic circuit breaker type B16A	36 pcs

Luminous

Lum. flux of luminaire	1920 lm
Lum. flux of light source	2710 lm
Luminaire efficacy	106 lm/W
Temperature	2700-6500 K
Rated life time LED L80/B10	100000 hours
CRI	Ra80
MacAdam	3
Blue light hazard	Risk group 0

Eulum data for calculation programs are available at www.osmont.cz.

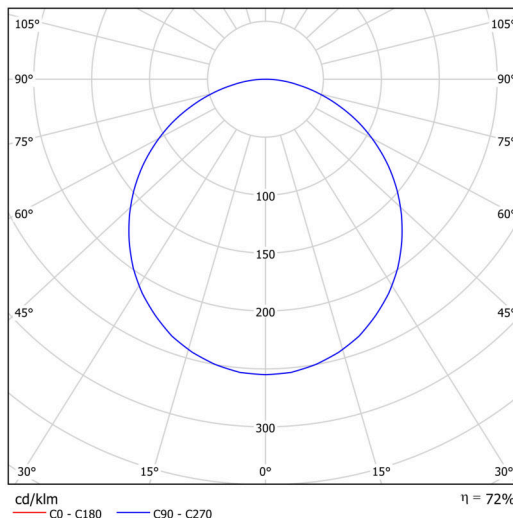
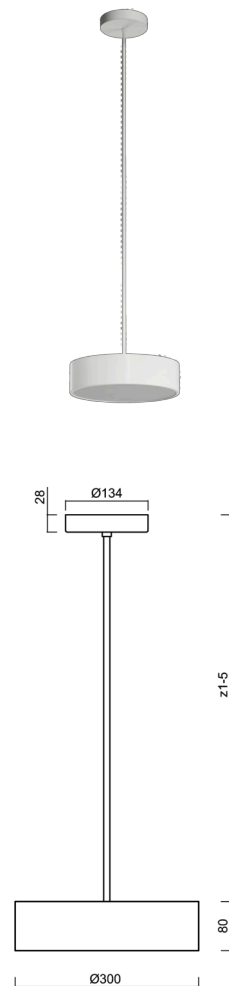

Logistic

EAN	8591728085582
Weight NTT0	2.8 Kg
Weight BTTO	3.6 Kg
Warranty*	60 months

*The warranty for the batteries is valid for 12 months from the date of purchase.

Installation dimensions:

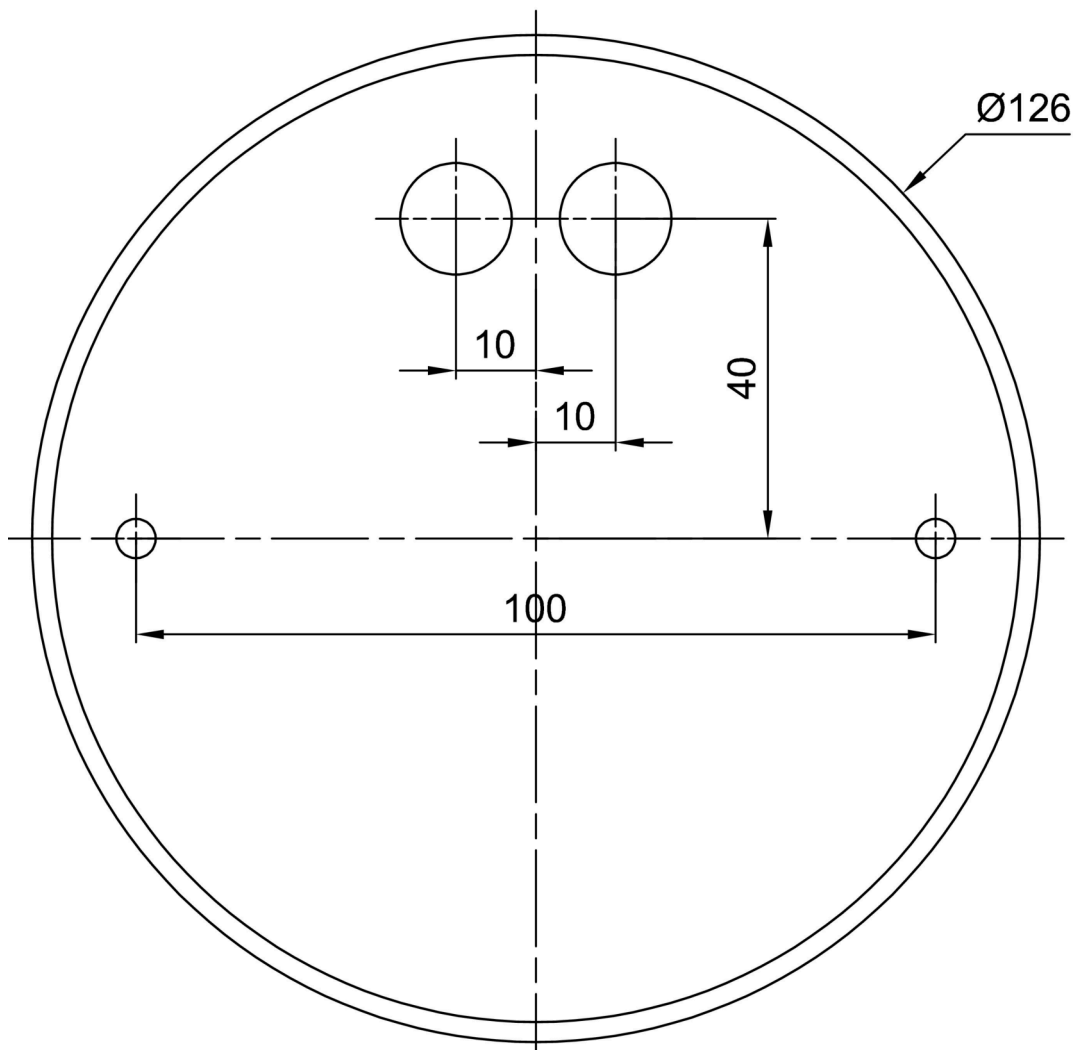

Additional assortment:

Lampshade

Product code	Name	Color	Description	Picture	Drawing
20631	F01B	white		