



## ERIS 2

---

LED-1L14EMP700K64/412/NK1W HF 4K#

[WWW.OSMONT.CZ](http://WWW.OSMONT.CZ)

# ERIS 2

Product code: ERI67511

Type: LED-1L14EMP700K64/412/NK1W HF 4K#

Short description of the luminaire: White surface-mounted LED light with emergency unit combined with sensor with TRIPLEX OPAL glass shade.

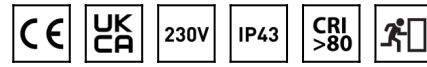

## Technical

Types of luminaires	Emergency combined + sensor
Mounting type	surface mounted
Base material	steel
Shade material	three-layer glass TRIPLEX OPAL
Base color	white Ral9003
Shade color	white
Holding the shade	folding system
Mounting location	ceiling/wall
Width	340 mm
Length	340 mm
Height	120 mm
Diameter	ø 340 mm
mounting holes (diameter)	4xø5mm
Installation wire (diameter)	2xø16mm
Energy Class	D
Impact strength	IK01
Operating temperature	from -20°C to +30°C

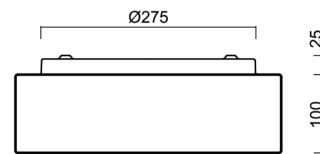
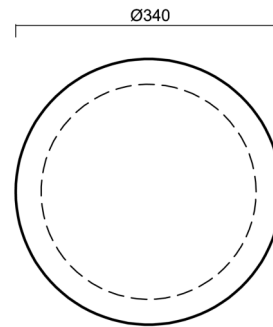

## Electric

Power consumption	18 W
Ingress Protection	IP43
Socket	LED modul
Sensor	HF
Battery type	NiCd
Emergency time	3 hours
terminal block	snap terminal block
Automatic circuit breaker type B10A	23 pcs
Automatic circuit breaker type B16A	36 pcs
Automatic circuit breaker type C10A	40 pcs
Automatic circuit breaker type C16A	64 pcs

## Luminous

Lum. flux of luminaire	1910 lm
Lum. flux of light source	2810 lm
Lum. flux of light source in emergency mode	150 lm
Luminaire efficacy	106 lm/W
Temperature	4000 K
Rated life time LED L80/B10	100000 hours
CRI	Ra80

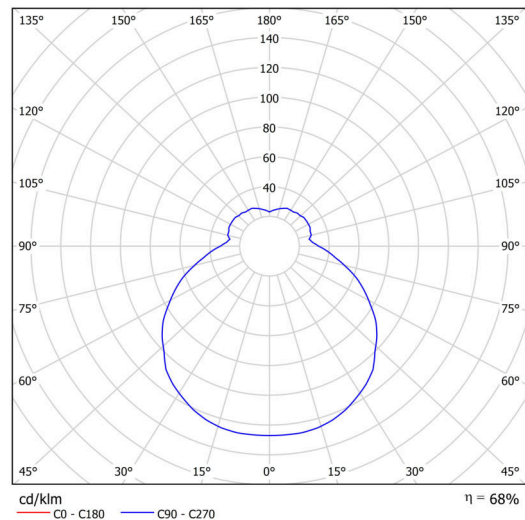

## TECHNICAL SHEET



MacAdam	3
Blue light hazard	Risk group 0

*Eulum data for calculation programs are available at  
www.osmont.cz.*

## Multipower

Possibility of output adjustment by the user (DIP switch on the current source).

I [mA]	700	650	600	550	500	450	400	350
[%]	100	93	86	79	71	64	57	50

## Logistic

EAN	8591728118709
Weight NTTO	3.35 Kg
Weight BTTO	3.55 Kg
Number of cartons	1 pcs
Package volume	0.019 m <sup>3</sup>
Package 1 width	0.35 m
Package 1 length	0.36 m
Package 1 height	0.15 m
Warranty*	60 months

*\*The warranty for the batteries is valid for 12 months from the date of purchase.*

## Installation dimensions:

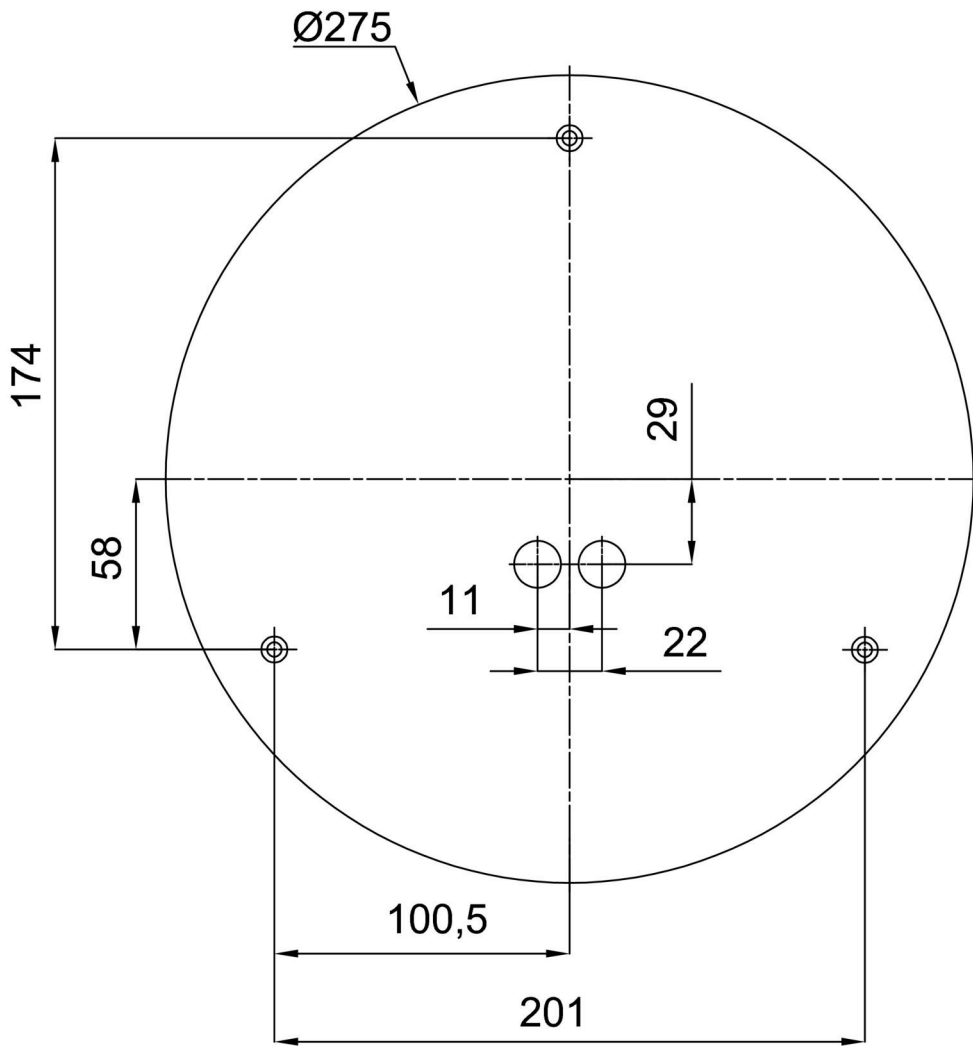

Additional assortment:

Lampshade

Product code	Name	Color	Description	Picture	Drawing
20123	412	white		