



ELEKTRA 4

LED-1L18E350/IN-172P HF 3K#

WWW.OSMONT.CZ

ELEKTRA 4

Product code: ELE57255

Type: LED-1L18E350/IN-172P HF 3K#

Short description of the luminaire: White industrial LED light with sensor and polycarbonate shade.



Technical

Types of luminaires	Sensor
Mounting type	industrial
Base material	polycarbonate
Shade material	opal polycarbonate
Base color	white Ra9003
Shade color	white
Holding the shade	screws
Mounting location	ceiling/wall
Width	260 mm
Length	260 mm
Height	110 mm
Diameter	ø 260 mm
mounting holes (diameter)	4xø5mm
Installation wire (diameter)	2xø14mm
Energy Class	D
Impact strength	IK10

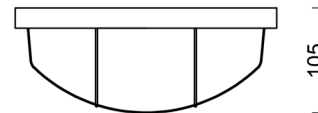
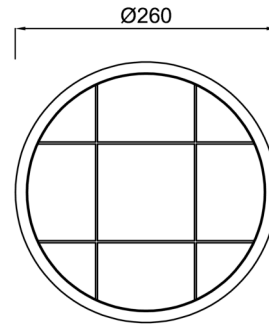

Electric

Power consumption	15 W
Ingress Protection	IP65
Socket	LED modul
Sensor	HF
terminal block	snap terminal block
Automatic circuit breaker type B10A	72 pcs
Automatic circuit breaker type B16A	116 pcs
Automatic circuit breaker type C10A	72 pcs
Automatic circuit breaker type C16A	116 pcs

Luminous

Lum. flux of luminaire	1780 lm
Lum. flux of light source	2230 lm
Luminaire efficacy	118 lm/W
Temperature	3000 K
Rated life time LED L80/B10	100000 hours
CRI	Ra80
MacAdam	3
Blue light hazard	Risk group 0

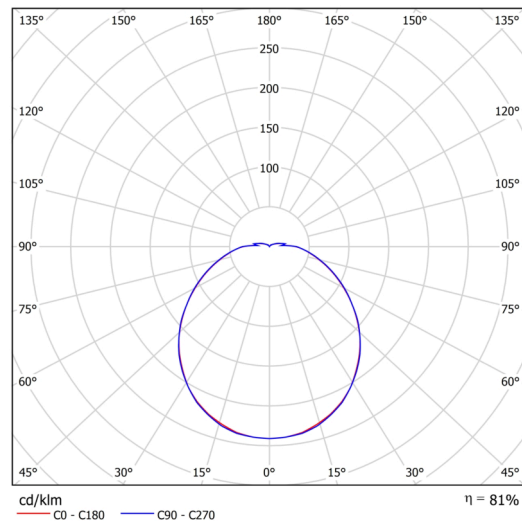

Eulum data for calculation programs are available at www.osmont.cz.

Logistic

EAN	8591728094959
Weight NTTO	0.85 Kg
Weight BTTO	1.05 Kg
Number of cartons	1 pcs
Package volume	0.009 m ³
Package 1 width	0.285 m
Package 1 length	0.27 m
Package 1 height	0.115 m
Warranty*	60 months

*The warranty for the batteries is valid for 12 months from the date of purchase.

Installation dimensions:

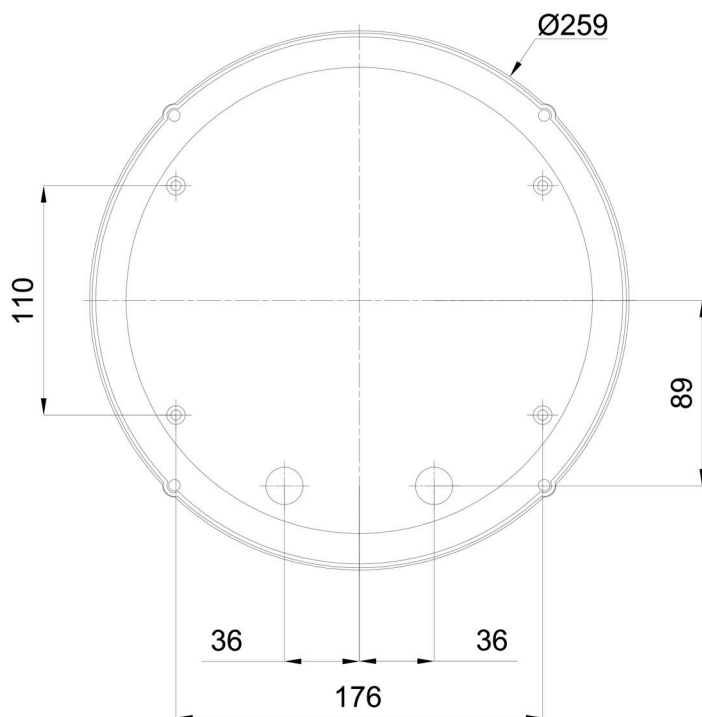

Additional assortment:

Lampshade

Product code	Name	Color	Description	Picture	Drawing
20552	172P	white		