



ELEKTRA 3

IN-152 H*

WWW.OSMONT.CZ

ELEKTRA 3

Product code: ELE50008

Type: IN-152 H*

Short description of the luminaire: Brown industrial E27 light ON/OFF and polycarbonate shade.

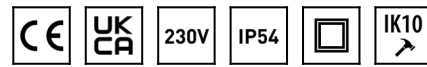

Technical

Types of luminaires	Classic on/off
Mounting type	industrial
Base material	polypropylene composite
Shade material	clear polycarbonate
Base color	brown Ral8017
Shade color	clear
Holding the shade	bayonet
Mounting location	ceiling/wall
Width	210 mm
Length	210 mm
Height	105 mm
Diameter	ø 210 mm
mounting holes (diameter)	4xø5mm
Installation wire (diameter)	2xø16mm
Impact strength	IK10
Operating temperature	from -20°C to +30°C

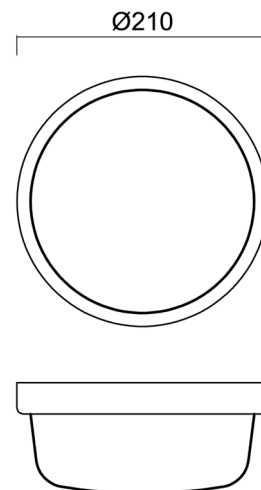

Electric

Voltage type	AC
AC voltage	220 - 240 V
Power consumption	25 W
Coverage class	2
Ingress Protection	IP54
Socket	E27
terminal block	none

Luminous

Blue light hazard	Risk group 0
-------------------	--------------

Eulum data for calculation programs are available at www.osmont.cz.

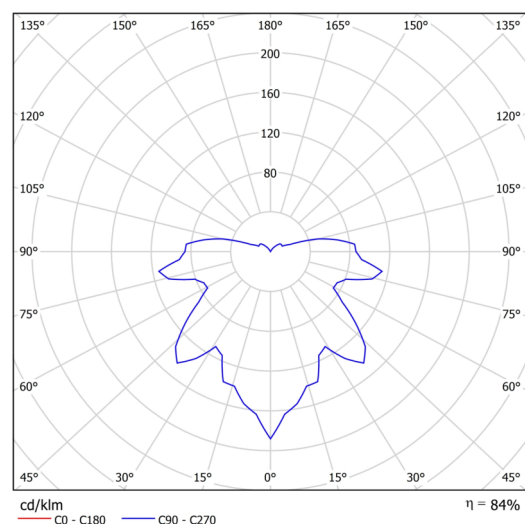

Logistic

EAN	8591728500085
Weight NTTO	0.5 Kg

TECHNICAL SHEET

Weight BTTO	0.6 Kg
Number of cartons	1 pcs
Package volume	0.005 m ³
Package 1 width	0.24 m
Package 1 length	0.23 m
Package 1 height	0.095 m
Warranty*	60 months

*The warranty for the batteries is valid for 12 months from the date of purchase.

Installation dimensions:

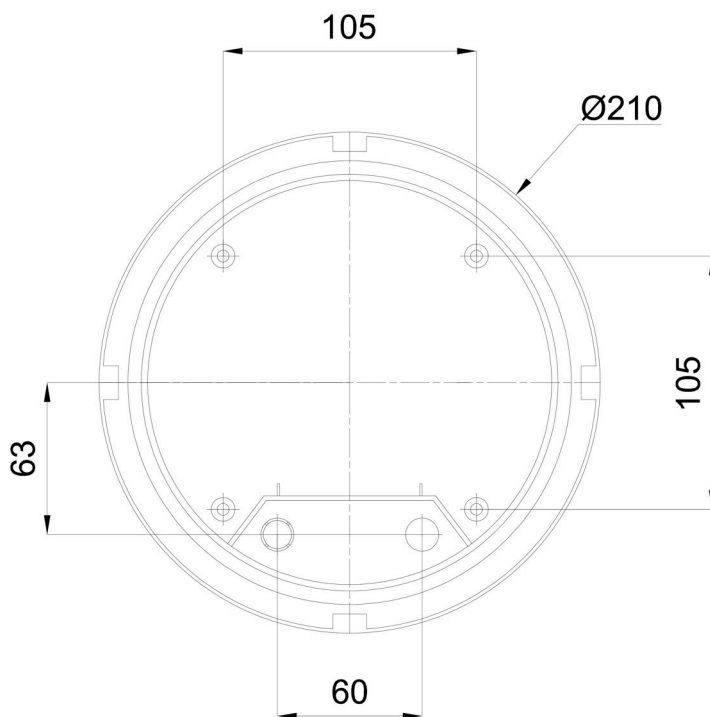

Additional assortment:

Lampshade

Product code	Name	Color	Description	Picture	Drawing
20500	152	white		