



DELIA LC5

LED-9L52EMP700ZLN11/PC26C/L100 3K##

WWW.OSMONT.CZ

DELIA LC5

Product code: DEL58857

Type: LED-9L52EMP700ZLN11/PC26C/L100 3K##

Short description of the luminaire: White colour | pendant LED light ON/OFF | multipower driver | opal polycarbonate shade (PC) with black decorative stripe | steel wire pendant (with supply cable) 100 cm |

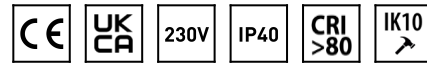

Technical data

Types of luminaires	Classic on/off
Mounting type	Suspended - wire
Base material	steel
Shade material	opal polycarbonate
Base color	white Ral9003
Shade color	white
Holding the shade	folding system
Mounting location	ceiling
Width	900 mm
Length	900 mm
Height	85 mm
Diameter	ø 900 mm
Suspension length	1000 mm
mounting holes (diameter)	2xø5mm
Cable entrance	2xø16mm
Energy Class	D
Impact strength	IK10
Operating temperature	from -20°C to +30°C

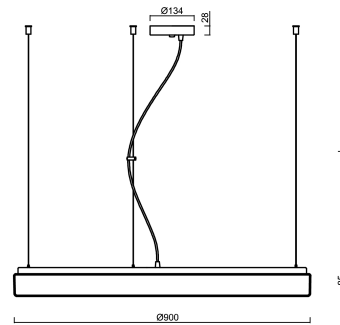

Electrical data

Power consumption	98 W
Ingress Protection	IP40
Socket	LED modul
terminal block	screw terminal block
Automatic circuit breaker type B10A	12 pcs
Automatic circuit breaker type B16A	19 pcs
Automatic circuit breaker type C10A	12 pcs
Automatic circuit breaker type C16A	19 pcs
Number of LED drivers	3

Luminous data

Lum. flux of luminaire	11050 lm
Lum. flux of light source	15780 lm
Luminaire efficacy	112 lm/W
Chromaticity temperature	3000 K
Rated life time LED L80/B10	100000 hours
CRI	Ra80
MacAdam	3
Blue light hazard	Risk group 0

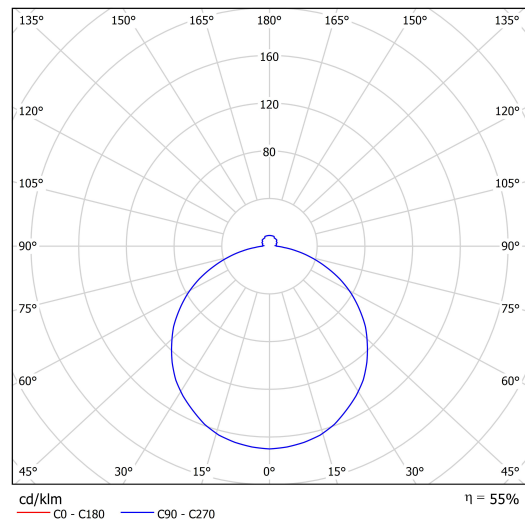

TECHNICAL SHEET



Enum data for calculation programs are available at www.osmont.cz.

Multipower

Possibility of output adjustment by the user (DIP switch on the current source).

I [mA]	700	650	600	550	500	450	400	
[%]	100	93	86	79	71	64	57	

Logistical data

EAN	8591728193508
Weight NTTO	10 Kg
Weight BTTO	12.7 Kg
Warranty*	60 months

*The warranty for the batteries is valid for 36 months from the date of purchase.

Installation dimensions:

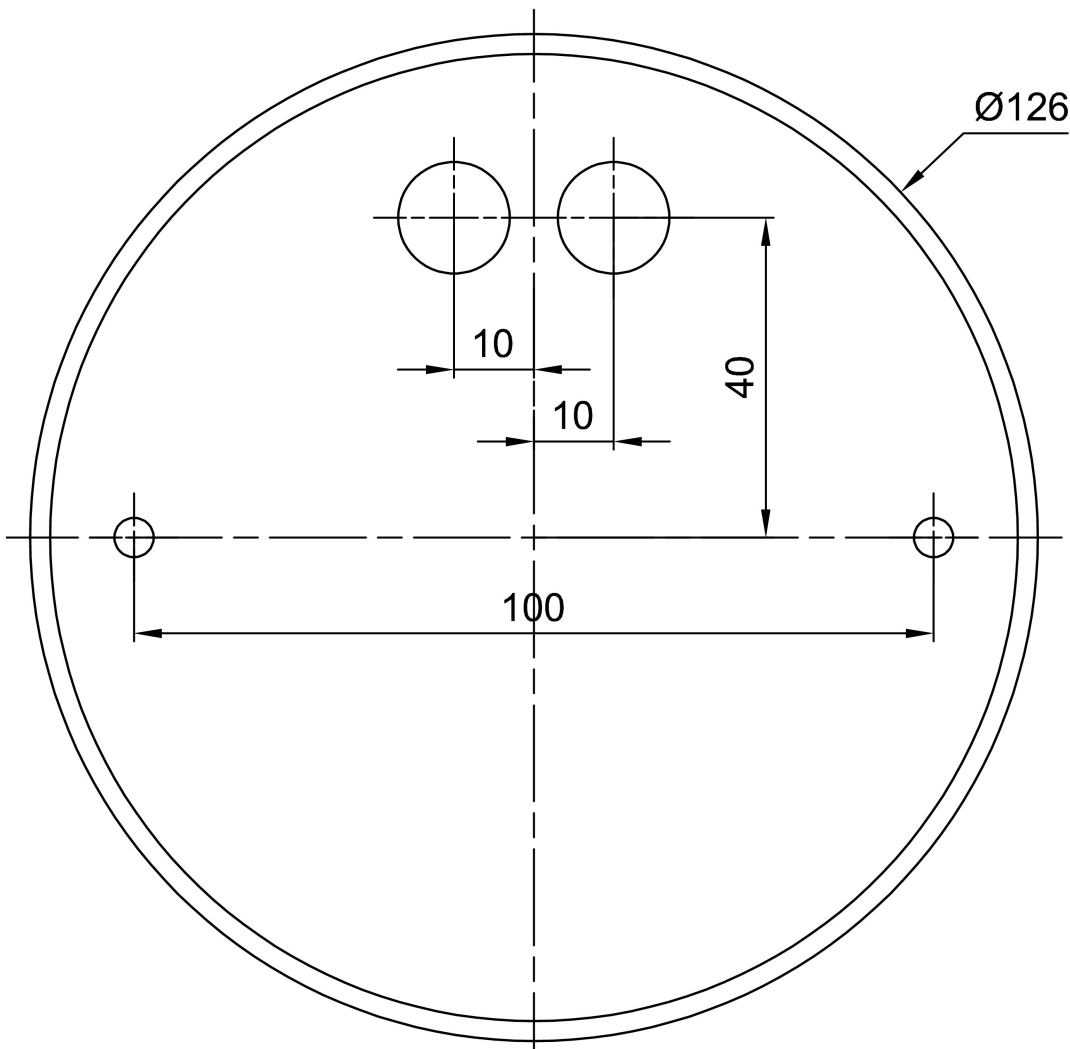

Additional assortment:

Lampshade

Product code	Name	Color	Picture	Drawing
20740	PC26C	white - black		