



DELIA C2A

LED-1L17E500KN73/PC19C/NK1W HF 4K#

WWW.OSMONT.CZ

DELIA C2A

Product code: DEL73519

Type: LED-1L17E500KN73/PC19C/NK1W HF 4K#

Short description of the luminaire: White color | surface-mounted LED light | emergency combi unit with microwave HF sensor | polycarbonate shade | black decorative foil stripe

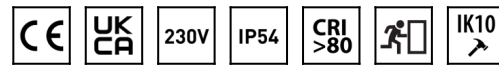

Technical

| | |
|------------------------------|-----------------------------|
| Types of luminaires | Emergency combined + sensor |
| Mounting type | surface mounted |
| Base material | steel |
| Shade material | opal polycarbonate |
| Base color | white Ral9003 |
| Shade color | white - black |
| Holding the shade | folding system |
| Mounting location | ceiling/wall |
| Width | 360 mm |
| Length | 360 mm |
| Height | 71 mm |
| Diameter | ø 360 mm |
| mounting holes (diameter) | 3xø5mm |
| Installation wire (diameter) | 2xø16mm |
| Energy Class | D |
| Impact strength | IK10 |
| Operating temperature | from -20°C to +30°C |

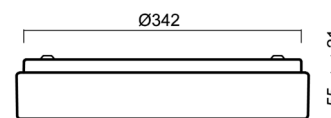
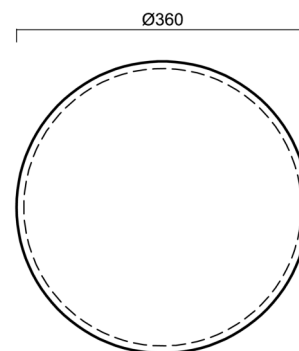

Electric

| | |
|-------------------------------------|---------------------|
| Power consumption | 17 W |
| Ingress Protection | IP54 |
| Socket | LED modul |
| Sensor | HF |
| Battery type | NiCd |
| Emergency time | 3 hours |
| terminal block | snap terminal block |
| Automatic circuit breaker type B10A | 26 pcs |
| Automatic circuit breaker type B16A | 40 pcs |
| Automatic circuit breaker type C10A | 30 pcs |
| Automatic circuit breaker type C16A | 48 pcs |

Luminous

| | |
|---|--------------|
| Lum. flux of luminaire | 1600 lm |
| Lum. flux of light source | 2900 lm |
| Lum. flux of light source in emergency mode | 150 lm |
| Luminaire efficacy | 94 lm/W |
| Temperature | 4000 K |
| Rated life time LED L80/B10 | 100000 hours |
| CRI | Ra80 |
| MacAdam | 3 |

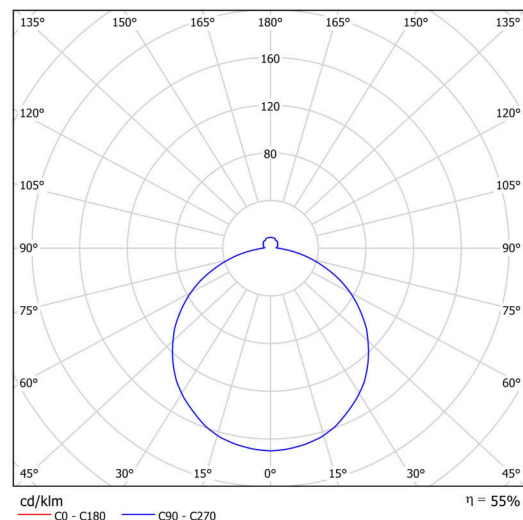

TECHNICAL SHEET



| | |
|-------------------|--------------|
| Blue light hazard | Risk group 0 |
|-------------------|--------------|

Eulum data for calculation programs are available at www.osmont.cz.

Logistic

| | |
|-------------------|----------------------|
| EAN | 8591728080365 |
| Weight NTTO | 1.65 Kg |
| Weight BTTO | 2.05 Kg |
| Number of cartons | 1 pcs |
| Package volume | 0.019 m ³ |
| Package 1 width | 0.385 m |
| Package 1 length | 0.37 m |
| Package 1 height | 0.13 m |
| Warranty* | 60 months |

*The warranty for the batteries is valid for 12 months from the date of purchase.

Installation dimensions:

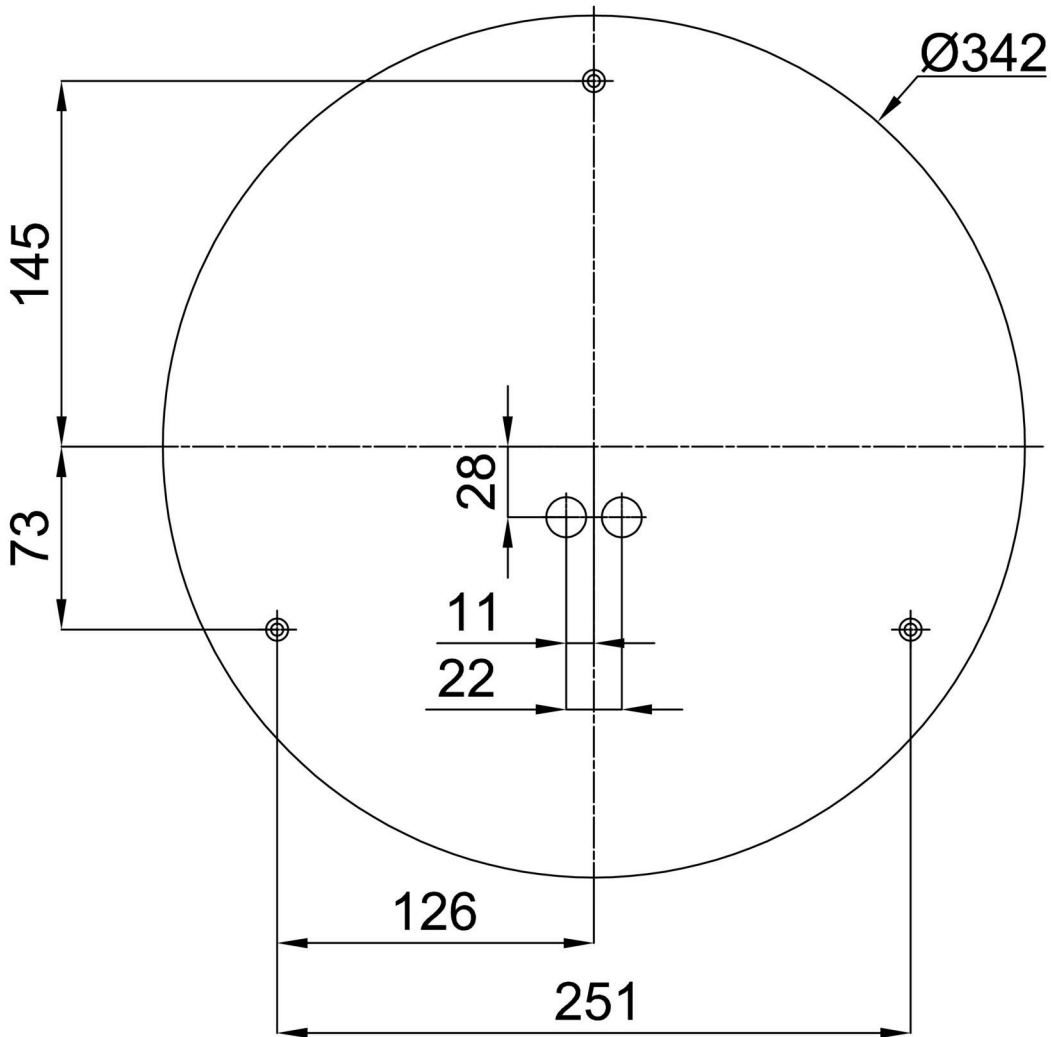

Additional assortment:

Lampshade

| Product code | Name | Color | Description | Picture | Drawing |
|--------------|-------|---------------|-------------|--|---------|
| 20567 | PC19C | white - black | |  | |