



TRITON 2

LED-1L15E700/IN-184 B DALI 3K#

WWW.OSMONT.CZ

Logistik

EAN	8591728133597
Gewicht NTTO	1.5 Kg
Gewicht BTTO	1.8 Kg
Anzahl kartons	1 Stck
Paketvolumen	0.019 m ³
Paket 1 breite	0.39 m
Paket 1 länge	0.37 m
Paket 1 höhe	0.13 m
Garantie*	60 Monate

*Die Garantie für die Batterien gilt für 12 Monate ab Kaufdatum.

Einbaumaße:

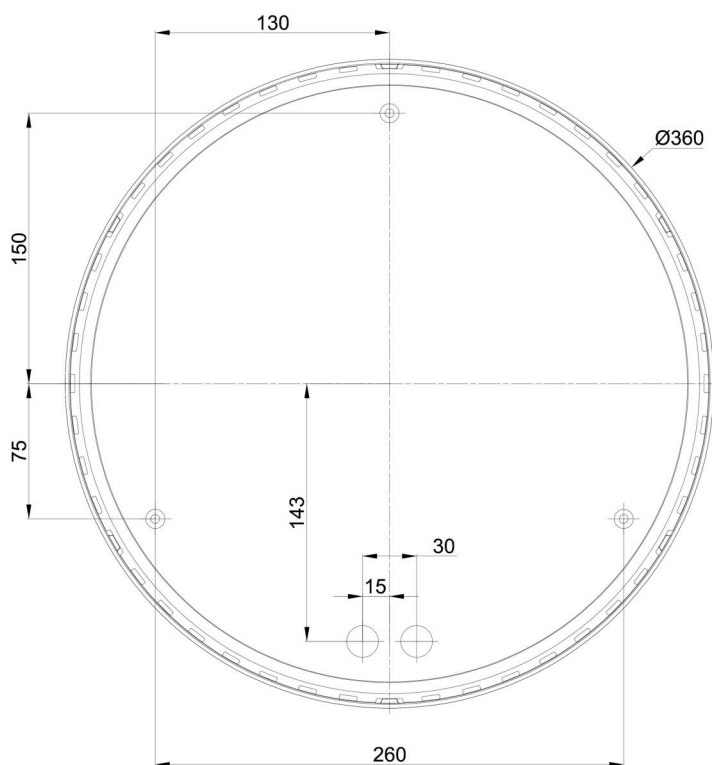

Zusätzliches Sortiment:

Lampenschirm

Produktcode	Name	Farbe	Beschreibung	Bild	Zeichnung
20550	184	Weiß			