



TITAN V3

IN-32KNV94/PM09 HF**

WWW.OSMONT.CZ

TITAN V3

Produktcode: TIT52524

Art: IN-32KNV94/PM09 HF**

Kurzbeschreibung der leuchte: Weiß Farbel Halbeinbauleuchte E27 EIN/AUS mit HF sensor | PMMA-Schirm

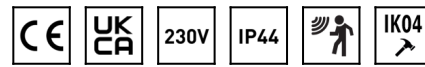

Technisch

Arten von leuchten	Sensor
Befestigungsart	Halbeinbauleuchten
Basismaterial	Stahl
Schattenmaterial	opales Polymethylmethacrylat
Grundfarbe	Weiß Ral9003
Schattenfarbe	Weiß
Schatten halten	Faltsystem
Montageort	Wand / Decke
Breite	500 mm
Länge	500 mm
Höhe	115 mm
Durchmesser	ø 500 mm
Montageloch	keiner
Kabeldurchgang	2xø16mm
Schlagfestigkeit	IK04
Betriebstemperatur	von -20°C bis +30°C

Elektrisch

Spannungstyp	AC
Wechselstrom Spannung	220 - 240 V
Energieverbrauch	3x25 W
Schutz vor Eindringen	IP44
Steckdose	E27
Sensor	HF
Klemme	Schnappklemmenblock

Leuchtend

Fotobiologische Sicherheit der Leuchte	Risk group 0
--	--------------

Eulum-Daten für Berechnungsprogramme sind unter www.osmont.cz verfügbar.

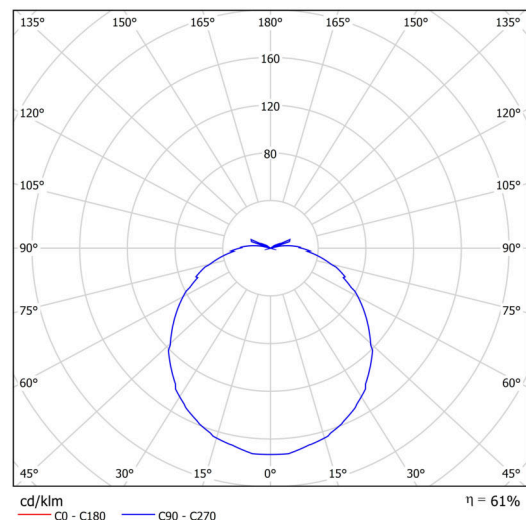
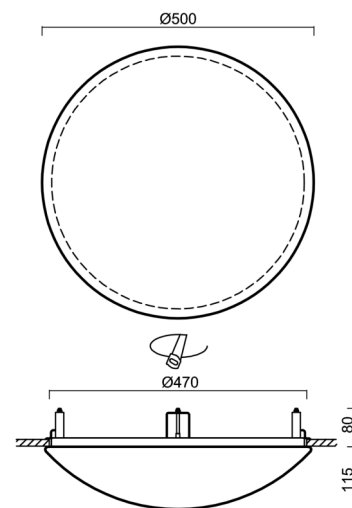

Logistik

EAN	8591728525248
Gewicht NTTO	2.45 Kg
Gewicht BTTO	2.95 Kg
Anzahl kartons	1 Stck
Paketvolumen	0.047 m ³
Paket 1 breite	0.51 m
Paket 1 länge	0.51 m
Paket 1 höhe	0.18 m
Garantie*	60 Monate

*Die Garantie für die Batterien gilt für 12 Monate ab Kaufdatum.

Einbaumaße:

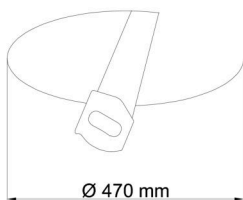

Svítlidlo nesmí být z horní strany zakryto izolací.
Luminaire must not be covered with insulating matting.

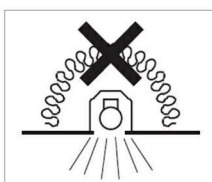

Rozměry dutiny pro vestavné svítidlo [mm]:
Dimensions of cavity for recessed luminaire [mm]:

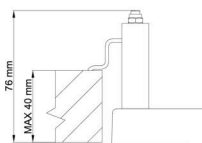
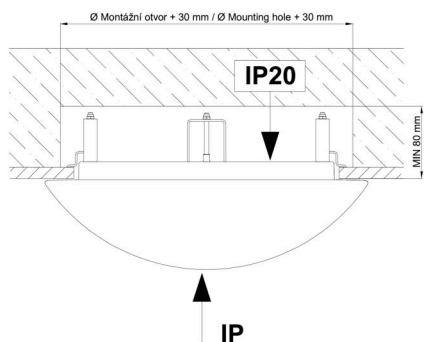

Montáž do pevných materiálů - sádkarton, dřevo.
Mounting into solid materials - plasterboard, wood.

Zusätzliches Sortiment:

Lampenschirm

Produktcode	Name	Farbe	Beschreibung	Bild	Zeichnung
20509	PM09	Weiß	příslušenství	