



## LUKIDA 2

---

LED-5L06E450BD1/194 KP 0 3K#

[WWW.OSMONT.CZ](http://WWW.OSMONT.CZ)



Logistik

EAN	8591728086336
Anzahl kartons	1 Stck
Garantie*	60 Monate

\*Die Garantie für die Batterien gilt für 12 Monate ab Kaufdatum.

Einbaumaße:

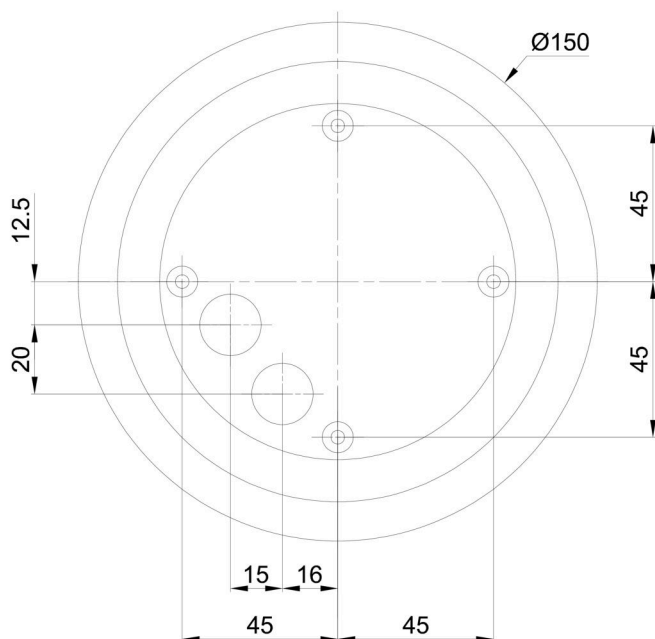

Zusätzliches Sortiment:

Sockel für Aufputzmontage

Produktcode	Name	Farbe	Beschreibung	Bild	Zeichnung
33521	BD1/BP 2-1	Weiß Ral9003			

Lampenschirm

Produktcode	Name	Farbe	Beschreibung	Bild	Zeichnung
20094	194	Weiß		