

CARINA LE2

LED-1L20E1000ZLEN96/426/L100 S DALI 3K##

WWW.OSMONT.CZ

Logistik

EAN	8591728010416
Gewicht NTTO	5.4 Kg
Gewicht BTTO	6.4 Kg
Anzahl kartons	1 Stck
Paketvolumen	0.091 m ³
Paket 1 breite	0.55 m
Paket 1 länge	0.55 m
Paket 1 höhe	0.3 m
Garantie*	60 Monate

*Die Garantie für die Batterien gilt für 12 Monate ab Kaufdatum.

Einbaumaße:

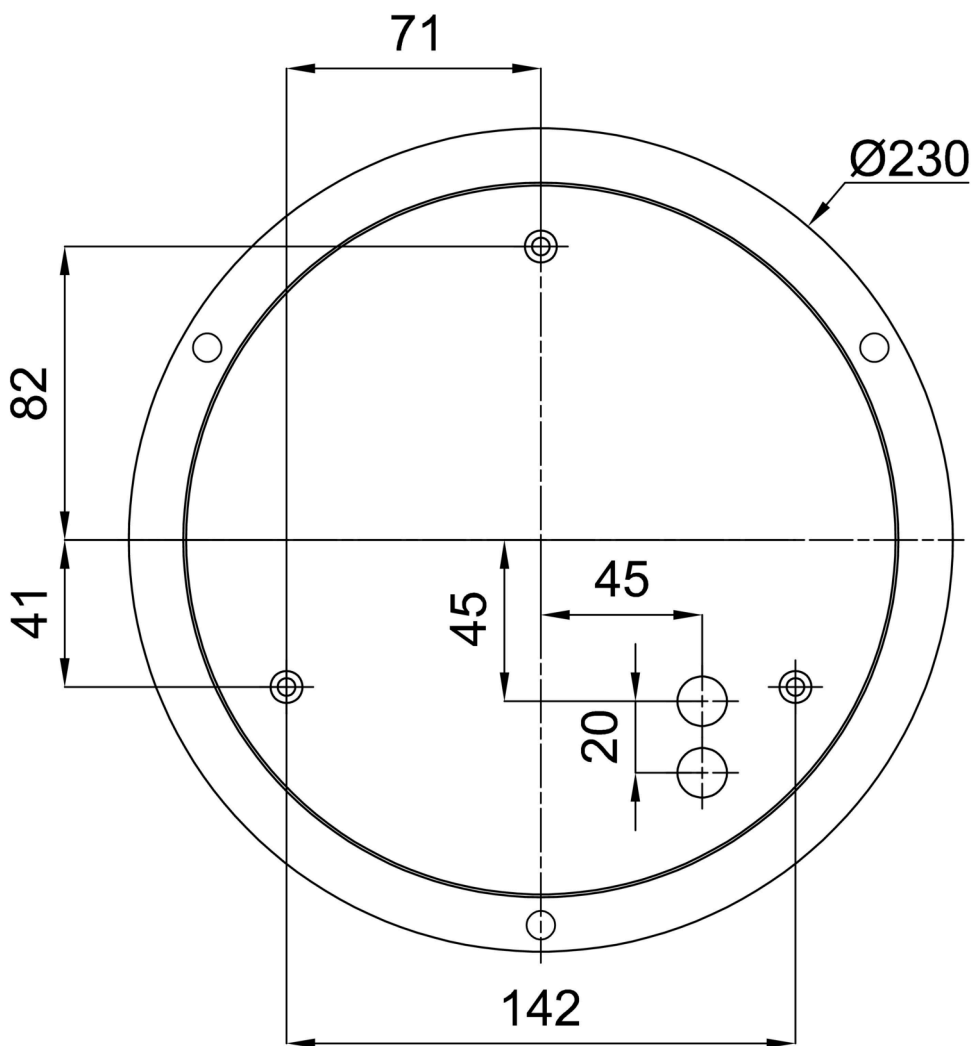

Zusätzliches Sortiment:

Lampenschirm

Produktcode	Name	Farbe	Beschreibung	Bild	Zeichnung
20116	426	Weiß		